



MRMODULE.COM.AU

FORD SMARTLOCK BYPASS MODULE

Ford Falcons from 1991-1999 used a 'Smartlock' anti-theft system. This module will re-produce the smartlock signal normally created by the BEM, allowing the engine computer (PCM) to run independently. The factory Smartlock / Body Electronics Module (BEM) or transponder ignition keys will no longer be required for the engine to run.

INSTALLATION

The bypass module should be mounted near the PCM (normally in the LH kick panel). It can be cable tied directly to the wiring loom using the mounting tabs.

The **Red** and **Black** should be spliced into the ignition and earth wires for the ECU.

The **Green** wire is the smartlock signal output. Cut the factory smartlock signal wire, and join it only to the bypass module output wire. Ensure the signal wire no longer runs to the rest of the vehicle

4 - Red	3 -
Ignition +12v	
2 - Black	1 - Green
Earth	Smartlock Signal

Molex 5557-04R / 39-01-2040 Connector
Back probe view (looking into module)

Wire	Function
Red	Ignition +12v
Black	Earth / Ground
Green	Smartlock Signal

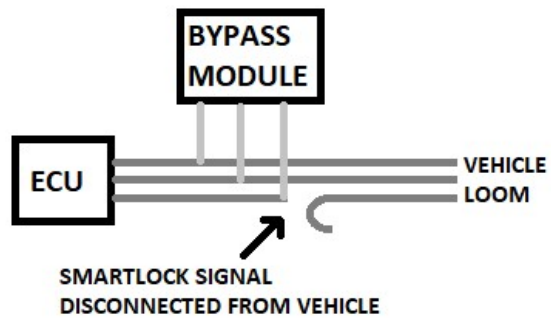

ECU PINOUT

Back-probe view, looking from wire side of connector.

The vehicles ECU will have either a 60 pin (EEC IV) or 104 pin (EEC V) connector.

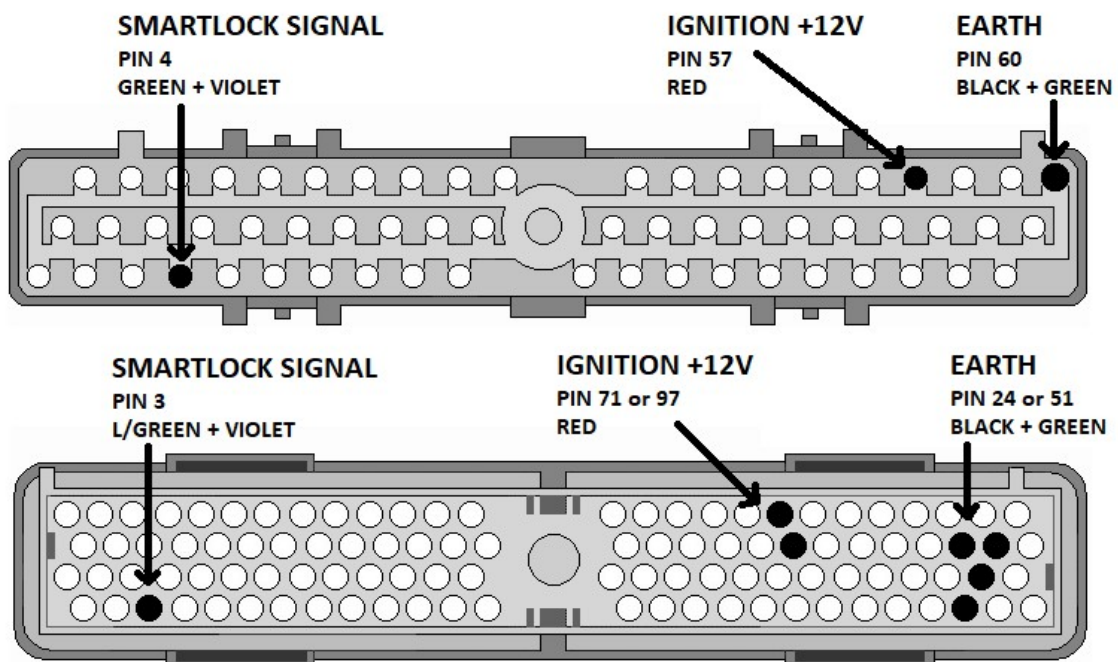

FACTORY STARTER CUT

The factory smartlock system includes a 'starter cut' feature. The factory smartlock/BEM module can disable the starter relay to prevent the engine from cranking. If the system has failed, you may need to join the 2 red + blue wires at the smartlock/BEM module to re-enable the starter relay.

Note: AU series 1 do not have the starter cut wires at the BEM

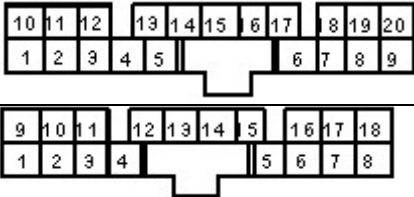
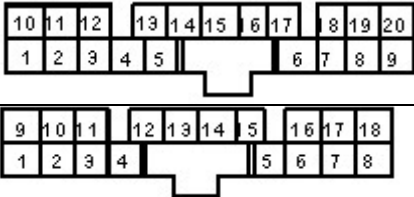
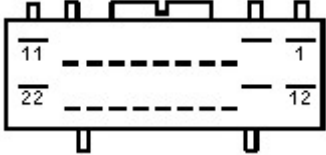
Model	Module Type	Wires to Join			
		Pin	Wire Colour	Connector Pinout	
XG / XH	Smartlock Module	18	Red/Blue		
		25	Red/Blue		
EB / ED / NC2	B.E.M	4	Red/Blue		
		17	Red/Blue		
EF / NF	B.E.M Low Series	8	Red/Blue		
		19	Red/Blue		
	B.E.M High Series	15	Red/Blue		
		16	Red/Blue		
EL / NL	B.E.M	11	Red/Blue		
		22	Red/Blue		

KILL SWITCH CONNECTION

The bypass module can be connected with a simple kill switch to prevent the engine starting. Use a toggle switch on the ignition +12v or earth wires of the module, ensuring it is only powered up when your kill switch is in the run position.

The kill switch needs to remain in the off position immediately and constantly from when the ignition is switched on. As soon as the bypass module is powered up, it will signal the ECU it is OK to run. The kill switch will not shut the engine down once the OK to run signal has been sent. It will only prevent it starting each ignition cycle.

SMARTLOCK WARNING LIGHT

If the factory smartlock system has failed, the warning light may remain on the dash even after the bypass module is fitted and the engine is running. The best solution is to remove the globe from the dash cluster.

DIAGNOSIS + TROUBLESHOOTING

The module can be tested for operation by checking DC voltage of the **Green/White** signal wire with a multimeter. It should read something other than 0v or 12v with ignition on. If the voltage is 0v, confirm power and earth connections.

If the vehicle has an underlying failure (such as a faulty fuel pump, starter motor or ignition system), the engine will still not run.

This module cannot fix other unrelated BEM functions that may not be working (such as central locking).

AU series 1 produced from approx. 06/1999 do not use Smartlock and this module is not suitable for them. Please check your ECU catch code at <https://mrmodule.com.au/ford-smartlock-smartshield/>